

Ultra & Ultra Multishot Rifle Instructions

IMPORTANT: Please read these instructions and view the CD-ROM before first using your rifle.



www.bsaguns.co.uk

NUMBER OF SHOTS (Approx)

	Carbine	Fill Pressure
.177 (12 ft lbs)	35 shots	232 bar
.22 (12 ft lbs)	40 shots	200 bar
.177 FAC	Not available	
.22 FAC 18 ft lbs	30 shots	232 bar



Gun Safety

- Make sure you know the laws relating to airguns, and abide by them.
- When you pick up any gun always check that it is not loaded.
- Never point a gun at anyone or anything that is not a legitimate target.
- Never leave your rifle unattended, even if it's unloaded.
- Gun safety is a state of mind; never rely on a safety catch.
- After use, put your rifle away safely; unloaded and out of reach of children. Store your pellets separately.
- Always ensure it is safe to shoot and be certain of your target before you squeeze the trigger.
- Make sure there is a safe backstop behind your target to catch your pellet in case you miss.
- Beware of ricochets – do not shoot at water or other smooth surfaces that may deflect the pellet in a different direction.
- Always unload your gun when crossing obstacles, taking it indoors or into a car.
- When carrying your rifle, be sure the muzzle is always pointing in a safe direction in case you should stumble.
- Never shoot on land without permission from the owner.

Safety Warning

- Use only dry breathing air.
- In the interest of safety any physical damage to air cylinders or filling tanks (e.g. dents, rust etc), and their fittings and valves must require the return of the item(s) to the manufacturer or their appointed agent for inspection.
- Any modification or service to the product must only be carried out by the manufacturer or their appointed agent. On no account should owners attempt to work on or modify guns.
- Do not exceed the manufacturers maximum fill pressure for the gun.
- Because of the high pressures involved the air reservoir should be checked periodically by the factory or an appointed agent of the company. BSA recommend a visual inspected every 3 years and pressure tested every 10 years.
- When storing your gun avoid excessive heat, cold or humidity.

Technical Information

All BSA airguns are made to the highest standards at our factory in Birmingham. BSA barrels are cold hammer forged and crowned for optimum accuracy.

Before leaving the factory, every airgun is tested on special purpose machinery to verify velocity and pellet grouping. UK law dictates that air rifles should not be capable of above 12 ft-lb of muzzle energy; all BSA models conform to this requirement. Export models are supplied to conform to the laws in the destination country.

Using Compressed Air

CAUTION!

Only dry breathing quality air should be used in guns. Never fill any gun with oxygen, or any other gas. Doing so could cause a serious explosion.

Never try to fill your gun with air when the rifle is in a partially assembled state.

The Ultra can be filled from an air tank or using a hand pump. Whichever equipment is used, a pressure gauge and supply hose bleed device must be included, and the manufacturers' instructions must always be followed.

Telescopic Sights

The BSA Ultra has a full length integral 10.8mm dovetailed scope rail designed to accept standard scope mounts and night vision equipment. Refer to the scope manufacturer's instructions on fitting and adjusting.

Filling the rifle with air

A filling adaptor is supplied with the rifle.

The maximum fill pressures for the Ultra and Ultra Multishot are shown in the table above. Do not over charge the rifle as this may be dangerous. Doing so will reduce the power and can damage the rifle.

- Before filling, always ensure the rifle is unloaded and the safety catch is on.
- Unscrew the end cap from the front of the air reservoir.
- If the air reservoir is empty, cock the rifle
- Insert the filling adaptor into the filling port, and push it home.
- Make sure the bleed screw on the charging unit is closed, and then open the air bottle valve slowly.
- Slowly fill the rifle to the maximum recommended charge pressure, and close the valve. Allow a few minutes for the pressure to settle. If necessary, repeat the procedure to top up the pressure in the gun
- Quickly open the air bleed valve on the charging unit to allow the pressurised air in the hose to escape.
- Pull the filling adaptor from the filling port and replace the end cap.
- Remember that your rifle may be cocked, if it is you should de-cock it immediately for safety reasons.
- To de-cock your rifle, release the safety catch, push the cocking knob in and hold firmly, pull trigger and slowly release the knob until it is back in the rest position.

Regularly check the condition of the filling probe "O" rings and apply a little Molycote 111 grease. Only use this grease on the "O" rings as automotive mineral oils and grease can cause an explosion if used with high-pressure air.

Loading the single shot Ultra

- Make sure the safety catch is in the rear (safe) position.
- Push down the probe release catch on the right hand side of the action.
- Place pellet in loading port.
- Push probe forward until the release catch pops up and holds the probe in position.
- To cock the rifle, press the cocking knob located under the reservoir until you hear a click as the trigger mechanism engages. The Ultra has been designed so that it can be cocked easily with a minimum of movement. Take the safety catch off when ready to fire the rifle.
- If you want to de-cock your rifle, push the cocking knob in and hold firmly, pull trigger and slowly release the knob until it is back in the rest position. Note the pellet remains in the barrel until the rifle is fired

The Ultra Multishot

The Magazine

The 10 shot capacity magazine features a rotor housed within a base, retained by a cover plate and screw. The rotor is sprung loaded and its movement is confined by a stop.

DO NOT TURN THE ROTOR AND RELEASE IT AGAINST THE SPRING PRESSURE AS THIS MAY DAMAGE THE STOP.

Take care to avoid contamination with dirt or grit and always carry magazines in a sealed plastic bag. Do not dismantle the magazine

Loading the Rifle

1. Apply the safety catch and push the magazine retaining catch forward.
2. Push down the pellet probe release catch on the right hand side of the action and remove the magazine.
3. Hold the magazine between finger and thumb with the cover plate screw uppermost. Push the pellet, nose first, into the empty magazine chamber and press down until the pellet skirt is under the cover plate.(Fig 1)
4. Rotate the magazine rotor anti - clockwise until the next empty chamber is revealed. Hold the rotor in this position against the spring pressure and load the next pellet into the chamber. (Fig 2)
5. Repeat this operation until all chambers have been loaded.
6. Replace the magazine in the rifle (Fig 3), close the magazine retaining catch and push the pellet probe forward. This will push the first pellet into the barrel chamber.
7. To cock the rifle, press the cocking knob located under the reservoir until you hear a click as the trigger mechanism engages. The Ultra has been designed so that it can be cocked easily with a minimum of movement. Take the safety catch off when ready to fire the rifle.
8. When the rifle has been fired, open the pellet probe only when you are ready to take the next shot. The magazine will automatically index to the next chamber when the pellet probe is re-opened and closed.

DO NOT OPEN THE PELLET PROBE MORE THAN ONCE WITHOUT FIRING AS THIS WILL LOAD MORE PELLETS INTO THE BARREL, POTENTIALLY CAUSING A BLOCKED BARREL AND DAMAGE TO THE RIFLE.



It is not necessary to re-cock the trigger mechanism until you are ready to take the next shot. After the first shot, you may prefer to cock the trigger mechanism prior to opening and closing the pellet probe, thus preventing accidental discharge of a pellet.

9. The magazine rotor is numbered to indicate the amount of pellets left in the magazine. Note the number will remain the same after the pellet has been fired and will change only when the Pellet probe is opened.
10. When the tenth and final pellet indexed into position, the number 1 will become visible. Once this pellet has been fired, the magazine is ready to be refilled.

Making a Loaded Rifle Safe

If the rifle has been loaded with a pellet, remove the magazine as described above, then close the pellet probe. Cock the rifle, aim at a safe target, take the safety catch off and fire. Do not refit the loaded magazine until it is needed, or remove all pellets from the magazine before refitting it to the rifle.

It is good practice to use this procedure once the rifle shoot has been completed, whether you know the magazine to be empty or otherwise.

Trigger Adjustment

Always ensure that your rifle is not cocked or loaded before adjusting the trigger. In the interests of safety, take care not to over-lighten the trigger weight.

The trigger is set at the factory, but some aspects can be adjusted to suit individual preferences.

1. Trigger pull. This screw adjusts the weight of second stage trigger pull, to increase the weight of pull turn the screw clockwise and anti-clockwise to reduce the weight of pull.

2. Sear engagement screw. This screw determines the length of the second stage release. Should you wish to adjust the length of the second stage release, slacken off the locknut and adjust the screw the desired amount. Turning the screw clockwise reduces the second stage release; turning it anti-clockwise increases the second stage release.

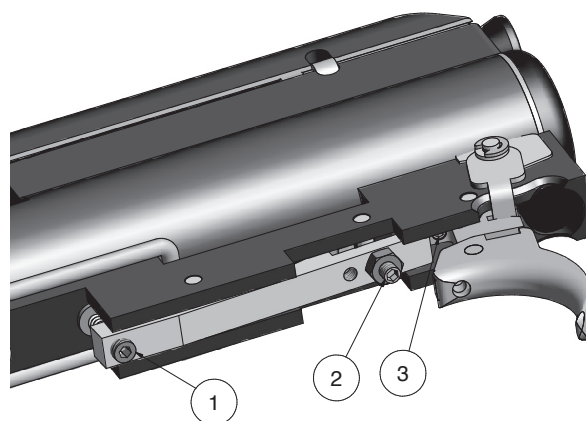

CAUTION. GREAT CARE SHOULD BE TAKEN IN THE ADJUSTMENT OF THIS SCREW. ANY EXCESSIVE CLOCKWISE TURN COULD RENDER THE RIFLE IN A CONDITION IN WHICH IT COULD FIRE ACCIDENTALLY. IF IN ANY DOUBT CONSULT A QUALIFIED GUNSMITH

3. First stage trigger adjustment, this is factory preset and must not be adjusted.

Care and Maintenance

After use, check that your rifle is unloaded and wipe the metal and woodwork surfaces with a lightly oiled cloth. Pay special attention to the metal finishes as these are not fully rustproof and are vulnerable to damp and particularly perspiration. If your rifle has become damp, make sure it is completely dry before you put it away.

Never use lubricants containing silicone as they can cause damage to metal surfaces. Application of oil and grease except as directed by the manufacturer can often do more harm than good.

Your rifle has been designed and manufactured for optimum performance. Tampering with the components, or unauthorised modifications and alterations may make the rifle unsafe to use and will invalidate the warranty. All air rifles require periodic maintenance and inspection, so even if everything seems to be in good working order, have your air rifle checked periodically by a competent gunsmith. You should always have the power of your air rifle re-checked following any maintenance or repair work as any repairs or adjustments could affect the power. **It is your legal responsibility to make sure the air rifle**

remains below the legal limit, which in the UK is 12 ft-lb.

The rifles air reservoir must always be kept in good condition. If any damage occurs, for example, denting, exposure to extreme temperatures or rust, the gun should be inspected by the manufacturer, or their appointed agent. The internal bore of the air cylinder must be inspected for corrosion periodically; which should not exceed 5 year intervals.

Diagrams and parts lists are available on our website at www.bsaguns.co.uk

2 Year Warranty All new BSA rifles carry a 2 year warranty against faulty parts and labour, this applies to new rifles only and is not transferable; proof of purchase is required. Excluded from this warranty are: failure due to misuse or abuse, the fitting of non-standard parts, and fair wear and tear. All warranty work must be done by BSA or an authorised agent of the company, and should the rifle be collected or returned under warranty, BSA or their authorised agent reserve the right to charge for postage and / or inspection. BSA will not accept guns for service or repair unless they are sent via a gun shop (RFD). So please do not return guns directly to the factory.

BSA GUNS (UK) Ltd. Armoury Road, Birmingham B11 2PP, England

BSA Guns (UK) Ltd, reserve the right to alter the designs or any constructional details of any product at any time without prior notice.

For the most up to date information on BSA products view our website at www.bsaguns.co.uk

© BSA Guns (UK) Ltd. Unauthorised sale, distribution, copying or reproduction of part or all of this material is not permitted without prior arrangement.