

# R-10 MK2 Rifle Instructions

**IMPORTANT: Please read these instructions before using your rifle for the first time.**

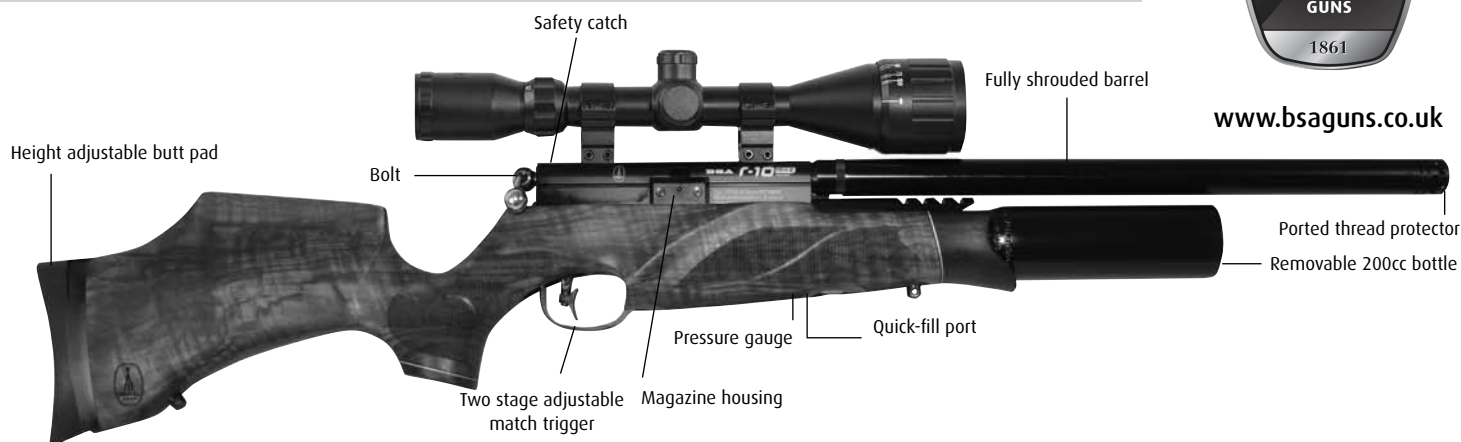

www.bsaguns.co.uk



## Gun Safety

- Make sure you know the laws relating to airguns, and abide by them.
- When you pick up any gun always check that it is not loaded.
- Never point a gun at anyone or anything that is not a legitimate target.
- Never leave your rifle unattended, even if it's unloaded.
- Gun safety is a state of mind; never rely on a safety catch.
- After use, put your rifle away safely; unloaded and out of reach of children. Store your pellets separately.
- Always ensure it is safe to shoot and be certain of your target before you squeeze the trigger.
- Make sure there is a safe backstop behind your target to catch your pellet in case you miss.
- Beware of ricochets – do not shoot at water or other smooth surfaces that may deflect the pellet in a different direction.
- Always unload your gun when crossing obstacles, taking it indoors or into a car.
- When carrying your rifle, be sure the muzzle is always pointing in a safe direction in case you should stumble.
- Never shoot on land without permission from the owner.

## Safety Warning

- Use only dry breathing air.
- In the interest of safety any physical damage to air cylinders or filling tanks (e.g. dents, rust etc), and their fittings and valves must require the return of the item(s) to the manufacturer or their appointed agent for inspection.
- Any modification or service to the product must only be carried out by the manufacturer or their appointed agent. On no account should owners attempt to work on or modify guns.
- Do not exceed the manufacturers maximum fill pressure for the gun.
- Because of the high pressures involved the air reservoir should be checked periodically by the factory or an appointed agent of the company. BSA recommend a visual inspected every 3 years and pressure tested every 10 years.
- When storing your gun avoid excessive heat, cold or humidity.

## Technical Information

All BSA airguns are made to the highest standards at our factory in Birmingham. BSA barrels are cold hammer forged and crowned for optimum accuracy.

Before leaving the factory every airgun is tested on special purpose machinery to verify velocity and pellet grouping. UK law dictates that air rifles should not be capable of above 12 ft-lb muzzle energy; all BSA models conform to this requirement. Export models are supplied to conform to the laws in the destination country.

## Using Compressed Air

### CAUTION!

Only dry breathing quality air should be used in guns.  
Never fill any gun with oxygen, or any other gas.

High pressure compressed air can be used safely provided proper procedures are followed, if you are not sure of the procedure ask your gun shop for advice.

Never try to fit a buddy bottle to the gun when the rifle is in a partially assembled state.

The removable buddy bottle can be filled from an air tank or using a hand pump. Whichever equipment is used, a pressure gauge and supply hose bleed device must be included, and the manufacturer's instructions must always be followed.

The buddy bottle can be removed and changed for a spare bottle in the field if required.

## Filling the rifle with air

A Quick – fill adaptor is supplied with the rifle.

The maximum fill pressure for the rifle is 232 BAR. Do not over charge the rifle as this may be dangerous. Doing so will reduce the power and can damage the rifle.

The buddy bottle can be filled with air in two ways;

1. Via the quick-fill port situated in front of the pressure gauge using the filling adaptor supplied with the gun.
2. By removing the bottle from the gun and refilling it using an optional bottle filling adaptor (part number 16-6440, not supplied) and replacing the bottle on the gun.

Unless you need to remove the buddy bottle it is recommended that the rifle is filled using the Quick –fill adaptor.

When filling the rifle via the quick fill port, use the gauge on the scuba tank or hand pump to read the pressure.

## Using the Quick-Fill

- Before filling, always ensure the rifle is unloaded and the safety catch is on.
- If the buddy bottle is empty, cock the rifle before filling.
- Insert the filling adaptor into the filling port, and push it home.
- Make sure the bleed screw on the charging unit is closed, and then open the air bottle valve slowly.
- Slowly fill the rifle to the maximum recommended charge pressure, and close the valve. Allow a few minutes for the pressure to settle. If necessary, repeat the procedure to top up the pressure in the gun
- Quickly open the air bleed valve on the charging unit to allow the pressurised air in the hose to escape.
- Pull the filling adaptor from the filling port.
- Remember that your rifle may be cocked, if so you should de-cock it immediately for safety reasons.
- To de-cock your rifle, release the safety catch, then pull back the bolt and while holding the bolt, pull the trigger and slowly allow the bolt to move forward until it is back in the rest position.

Regularly check the condition of the filling probe "O" rings and apply a little Molycote 111 grease. Only use this grease on the "O" rings as automotive mineral oils and grease can cause an explosion if used with high-pressure air.

## Removing the Buddy Bottle

- Apply the safety catch, remove the magazine and check that there is not a pellet in the barrel, if in doubt point the rifle in a safe direction and fire the rifle to ensure that the barrel is clear.
- To avoid damage to the buddy bottle "O" ring, which can result in leaks, it is essential to first close the valve in the buddy bottle by unscrewing it one full turn. There will still be some compressed air in the rifle's regulator. To release this, point the gun in a safe direction, take off the safety catch and fire the gun several times. Repeat the firing-cycle until the muzzle discharge becomes quieter and the pressure gauge reads empty.
- If the muzzle report is still loud after firing the gun 8-10 shots and the gauge is still showing air in the gun, unscrew the bottle a further quarter turn and repeat the process. Once the rifle is empty the bottle can easily be un-screwed.

## Filling the Bottle with Air

An optional filling adaptor which screws onto the top of the buddy bottle (part number 16-6440, not supplied) is obtainable from BSA stockists.

- Check that the threads on the bottle and filling adaptor are clean, then screw the bottle into the adaptor until it is tight.
- The procedure for refilling the bottle is identical to that when using the filling probe.

## Telescopic Sights

The BSA R-10 mk2 has a full length integral 10.8mm dovetailed scope rail designed to accept standard scope mounts and night vision equipment. Refer to the scope manufacturer's instructions on fitting and adjusting.

## Butt Plate

The butt plate can be adjusted for elevation to suit your individual preference. Loosen the central locking screw and find the position that best matches your ideal sighting and comfort. Tighten the screw to lock the plate.

## The Magazine

The 10 shot capacity magazine features a rotor housed within a base, retained by a cover plate and screw. The rotor is sprung loaded and its movement is confined by a stop.

**DO NOT TURN THE ROTOR AND RELEASE IT AGAINST THE SPRING PRESSURE AS THIS MAY DAMAGE THE STOP.**

**Take care to avoid contamination with dirt or grit and always carry magazines in a sealed plastic bag. Do not dismantle the magazine**

## Loading the Rifle

1. Apply the safety catch and push the magazine retaining catch forward.
2. Lift the bolt handle and pull back as far as it will go and while holding the bolt in this position, remove the magazine.
3. Hold the magazine between finger and thumb with the cover plate screw uppermost. Push the pellet, nose first, into the empty magazine chamber and press down until the pellet skirt is under the cover plate. (Fig 1)
4. Rotate the magazine rotor anti-clockwise until the next empty chamber is revealed. Hold the rotor in this position against the spring pressure and load the next pellet into the chamber. (Fig 2)
5. Repeat this operation until all chambers have been loaded.
6. Replace the magazine in the rifle (Fig 3), close the magazine retaining catch and close the bolt. Take the safety catch off when ready to fire the rifle.
7. When the rifle has been fired, the magazine will automatically index to the next chamber when the rifle is re-cocked. Close the bolt and the rifle is ready for the next shot. **DO NOT RECOCK THE RIFLE MORE THAN ONCE WITHOUT FIRING AS THIS WILL LOAD MORE PELLETS INTO THE BARREL, POTENTIALLY CAUSING A BLOCKED BARREL AND DAMAGE TO THE RIFLE**
8. The magazine rotor is numbered to indicate the amount of pellets left in the magazine. Note the number will remain the same after the pellet has been fired and will change only when the rifle is re-cocked.
9. When the tenth and final pellet indexed into position, the number 1 will become visible. Once this pellet has been fired, the magazine is ready to be refilled.

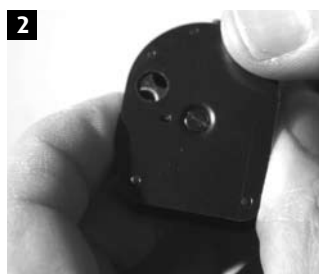

## Making a loaded rifle safe

If the rifle has been loaded with a pellet, remove the magazine as described above, then close the bolt, aim the rifle at a safe target, take the safety catch off and fire. Do not refit the loaded magazine until it is needed, or remove all pellets from the magazine before refitting it to the rifle.

It is good practice to use this procedure once the rifle shoot has been completed, whether you know the magazine to be empty or otherwise.

## The Silencer

The BSA R-10 mk2 has a shrouded barrel, incorporating a highly efficient sound suppression system. There is a ported muzzle break which acts as a thread protector and when removed reveals a 1/2" UNF thread allowing the use of an additional silencer if desired.

## Trigger Adjustments

The trigger is set at the factory, but some aspects can be adjusted to suit individual preferences.

Before adjusting the trigger, remove the magazine and check that there is not a pellet in the barrel, if in doubt point the rifle in a safe direction and fire the rifle to ensure that the barrel is clear.

Remove the Buddy Bottle as described previously, then remove the stock assembly.

In the interests of safety, take care not to over-lighten the trigger weight.

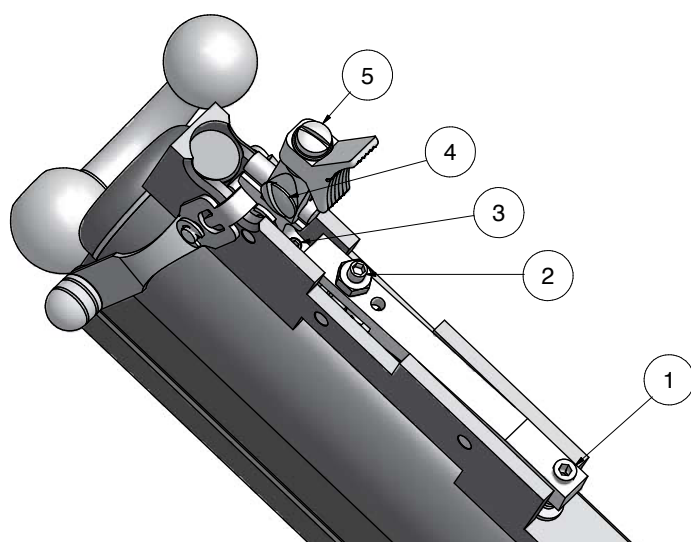

**1. Trigger pull.** This screw adjusts the weight of second stage trigger pull, to increase the weight of pull turn the screw clockwise and anti-clockwise to reduce the weight of pull.

**2. Sear engagement screw.** This screw determines the length of the second stage release. Should you wish to adjust the length of the second stage release, slacken off the locknut and adjust the screw the desired amount. Turning the screw clockwise reduces the second stage release; turning it anti-clockwise increases the second stage release.

**CAUTION GREAT CARE SHOULD BE TAKEN IN THE ADJUSTMENT OF THIS SCREW. ANY EXCESSIVE CLOCKWISE TURN COULD RENDER THE GUN IN A CONDITION IN WHICH IT COULD FIRE ACCIDENTALLY. IF IN ANY DOUBT CONSULT A QUALIFIED GUNSMITH**

**3. First stage trigger adjustment.** This is factory preset and must not be adjusted.

**4. The trigger grip can be adjusted lengthways, sideways and swivelling using screws 4 and 5.** It is not necessary to remove the stock to carry out these adjustments.

## Care and Maintenance

After use, check that your rifle is unloaded and wipe the metal and woodwork surfaces with a lightly oiled cloth. Pay special attention to the metal finishes as these are not fully rustproof and are vulnerable to damp and particularly perspiration. If your rifle has become damp, make sure it is completely dry before you put it away.

The R-10 mk2 has a grade 2 walnut stock with an oil finish. Periodic application of a small amount of a proprietary stock finishing oil is all that is required. Alternatively linseed or walnut oil could be used.

Never use lubricants containing silicone as they can cause damage to metal surfaces. Application of oil and grease except as directed by the manufacturer can often do more harm than good.

Your rifle has been designed and manufactured for optimum performance. Tampering with the components, or unauthorised modifications and alterations may make the rifle unsafe to use and will invalidate the warranty. All air rifles require periodic maintenance and inspection, so even if everything seems to be in good working order, have your air rifle

checked periodically by a competent gunsmith. You should always have the power of your air rifle re-checked following any maintenance or repair work as any repairs or adjustments could affect the power. It is your legal responsibility to make sure the air rifle remains below the legal power limit, which in the UK is 12 ft-lb.

Diagrams and parts lists are available on our website at [www.bsaguns.co.uk](http://www.bsaguns.co.uk)

### 2 Year Warranty

All new BSA rifles carry a 2 year warranty against faulty parts and labour, this applies to new rifles only and is not transferable; proof of purchase is required. Excluded from this warranty are: failure due to misuse or abuse, the fitting of non-standard parts, and fair wear and tear. All warranty work must be done by BSA or an authorised agent of the company, and should the rifle be collected or returned under warranty, BSA or their authorised agent reserve the right to charge for postage and / or inspection. BSA will not accept guns for service or repair unless they are sent via a gun shop (RFD). So please do not return guns directly to the factory.